

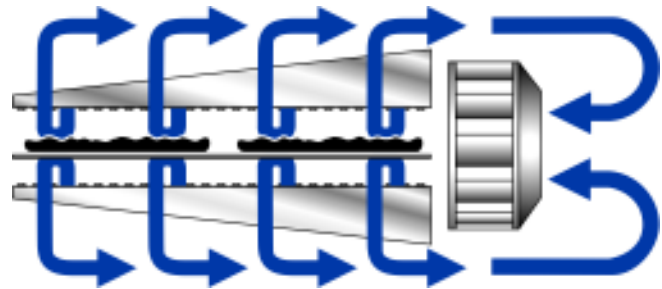

Principle

Middleby Marshall PS Series conveyor ovens bake both faster and at a lower temperature than other ovens. Patented vertical columns of hot air move heat aerodynamically instead of using high temperatures. The streams of hot air remove the boundary layers of cool heavy air which tend to insulate the product. This gives very rapid baking without burning. All Middleby ovens are designed to cook a multitude of products including pizza, seafood, bagels, ethnic foods and more.



Standard Features

- **Impingement PLUS!** low oven profile and dual air return
- **Patented EMS Energy Management System** reduces gas consumption and increases cooking efficiency
- 55"/1397mm-long cooking chamber
- 32"/813mm-wide, 90"/2286mm-long conveyor belt
- Stackable up to four units high
- Patented "Jet Sweep" impingement process that delivers constant heat to the chamber
- Microprocessor-controlled bake time/conveyor speed
- Customer-specific adjustable jet fingers that allow control of heat delivery
- Stainless steel front, sides and top
- Front-loading window with cool handle
- Reversible conveyor direction

Optional Features

- Split belt - two 15"/381mm belts with individually-adjustable speed settings

Conserves Energy

Middleby ovens provide very efficient heat transfer to product. Energy is conserved as air is recycled from heater to product, with minimum flue or vent loss.

Cleanability

PS555 ovens are designed for easy cleaning. Removable parts include: crumb pans, end panels, air fingers, and a folding conveyor belt assembly.

Easily Serviced

Control compartment is designed for quick and easy access. Primary electrical components are door-mounted.

Warranty

All PS555 models have a one year parts and labor warranty. Oven start-up and demonstration are included at no additional charge (USA only).

Ventilation

For installation under a ventilation hood only.



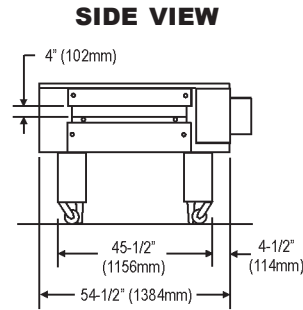
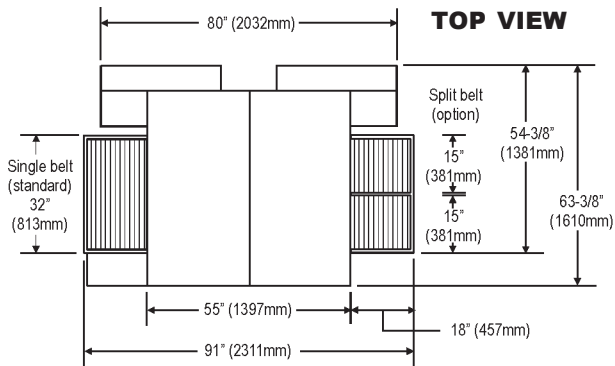

- ① Gas Utility Connection
- ② Electrical Utility Connection

**PS555-1 Single Oven
with 15" (381mm) leg extensions**

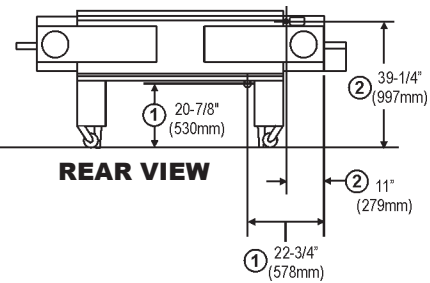
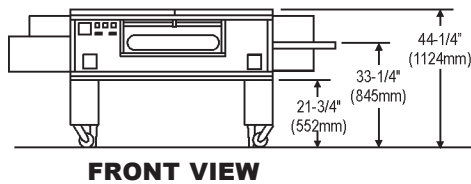

**PS555-1 Single Oven
with 19" (483mm) leg extensions**

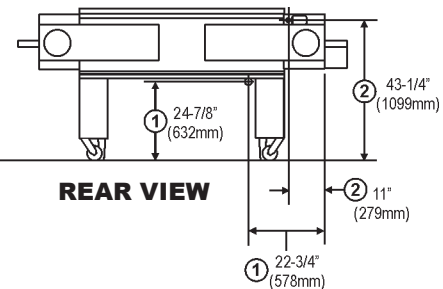
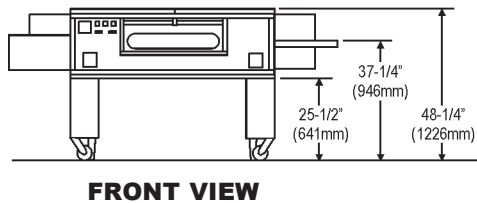

**PS555-2 Double Oven
with 10" (254mm) leg extensions**

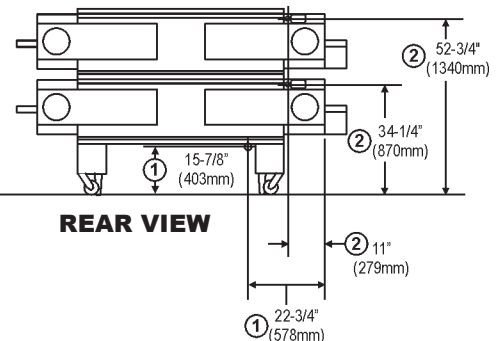
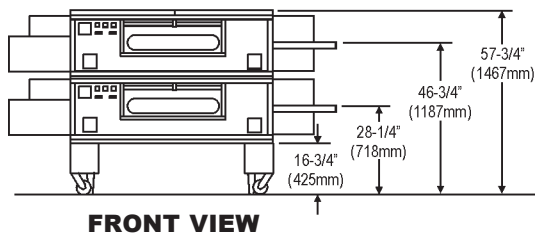

PS555-2 Double Oven with 15" (381mm) leg extensions

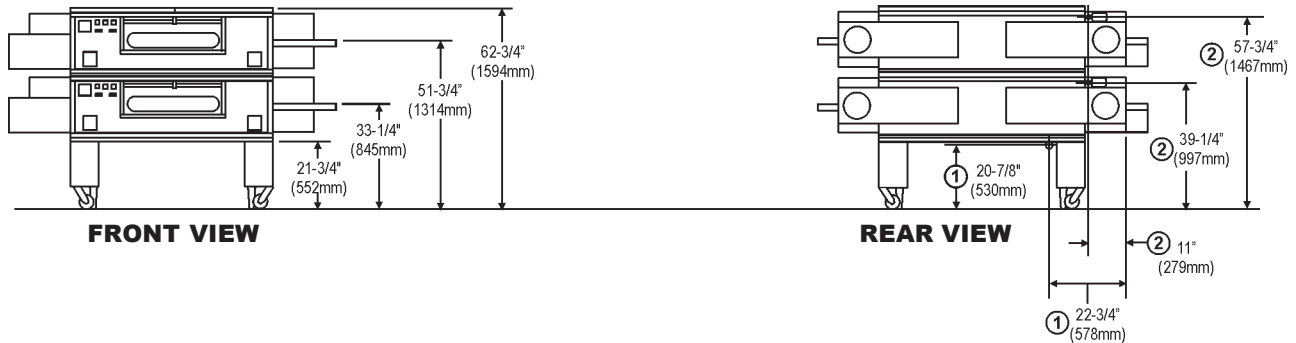

PS555-3 Triple Oven without leg extensions

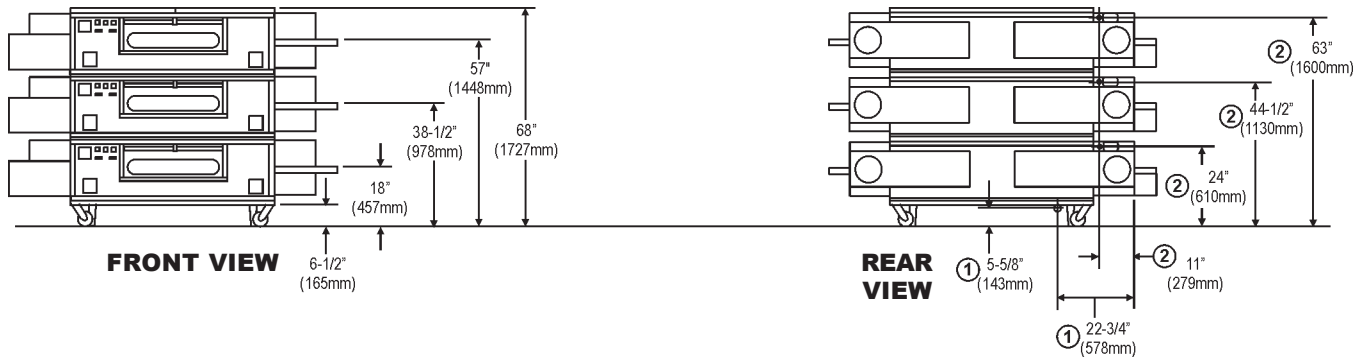

PS555-3 Triple Oven with 4" (102mm) leg extensions

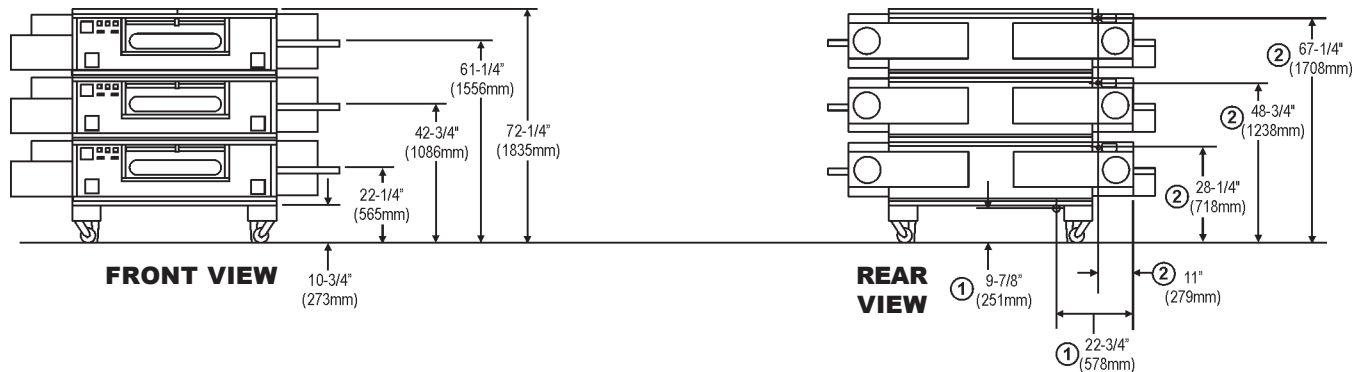

PS555-4 Quad Oven with outriggers

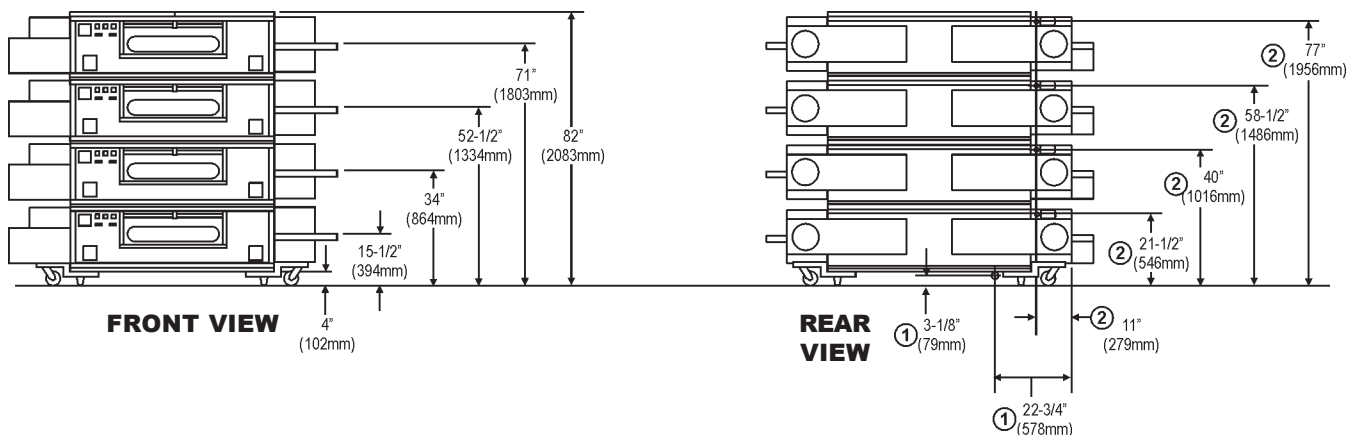



RECOMMENDED MINIMUM CLEARANCES

Rear of oven to wall	Control end of oven to wall	Non-control end of oven to wall
0" (0mm)	0" (0mm)	0" (0mm)

GENERAL INFORMATION

	Heating Zone	Baking Area	Belt Length	Conveyor Belt Width	Depth	Height	Max. Temp.	Bake Time Range	Ship Wt.	Ship Cube
PS555-1 with 15" (254mm) leg extensions	55" 1397mm	12.2 sq. ft. 1.13m ²	91" 2311mm	1 x 32" (813mm) OR 2 x 15" (381mm)	63-3/8" 1584mm	44-1/4" 1124mm	550°F 288°C	4- 29:50	1250 lbs. 568kg	160 ft. ³ 4.5m ³
PS555-1 with 19" (483mm) leg extensions	55" 1397mm	12.2 sq. ft. 1.13m ²	91" 2311mm	1 x 32" (813mm) OR 2 x 15" (381mm)	63-3/8" 1584mm	48-1/4" 1226mm	550°F 288°C	4- 29:50	1250 lbs. 568kg	160 ft. ³ 4.5m ³
PS555-2 with 10" (254mm) leg extensions	110" 2794mm	24.4 sq. ft. 2.27m ²	91" 2311mm	1 x 32" (813mm) OR 2 x 15" (381mm)	63-3/8" 1584mm	57-3/4" 1467mm	550°F 288°C	4- 29:50	2500 lbs. 1135kg	320 ft. ³ 9.0m ³
PS555-2 with 15" (381mm) leg extensions	110" 2794mm	24.4 sq. ft. 2.27m ²	91" 2311mm	1 x 32" (813mm) OR 2 x 15" (381mm)	63-3/8" 1584mm	62-3/4" 1594mm	550°F 288°C	4- 29:50	2500 lbs. 1135kg	320 ft. ³ 9.0m ³
PS555-3 without leg extensions	165" 4191mm	36.6 sq. ft. 3.40m ²	91" 2311mm	1 x 32" (813mm) OR 2 x 15" (381mm)	63-3/8" 1584mm	68" 1727mm	550°F 288°C	4- 29:50	3750 lbs. 1703kg	480 ft. ³ 13.5m ³
PS555-3 with 4" (102mm) leg extensions	165" 4191mm	36.6 sq. ft. 3.40m ²	91" 2311mm	1 x 32" (813mm) OR 2 x 15" (381mm)	63-3/8" 1584mm	72-1/4" 1835mm	550°F 288°C	4- 29:50	3750 lbs. 1703kg	480 ft. ³ 13.5m ³
PS555-4 with outriggers	220" 5588mm	48.8 sq. ft. 4.54m ²	91" 2311mm	1 x 32" (813mm) OR 2 x 15" (381mm)	63-3/8" 1584mm	82" 2083mm	550°F 288°C	4- 29:50	5000 lbs. 2270kg	640 ft. ³ 18.0m ³

ELECTRICAL SPECIFICATIONS

Model	Version	Voltage	Phase/Freq.	Supply
PS555		208-240V	1/60 Hz	2 pole, 3 wire (2 hot, 1 gnd)
PS555		230V	1/50 Hz	2 pole, 3 wire (2 hot, 1 gnd)

Max Current Draw at Startup







Amperage
12A*
10A*

Breakers

As per local codes
As per local codes

* The current draw ratings shown above are the max required at startup. The average current draw during operation is significantly lower.

GAS SUPPLY SPECIFICATIONS

Version	Gas Type	Supply (inlet) Pressure (mbar)							Rated Heat Input
		North America	IE, IT, PT, ES, GB II _{2H3+}	DE II _{2ELL3B/P}	NL II _{2L3B/P}	BE, FR II _{2E+3+}	AT, CH, DK, FI, SE II _{2H3B/P}		
	Natural Gas	6-12" W.C. (14.9-29.9mbar)	-	-	-	-	-	150,000 BTU (44kW-hr.)	
	Propane Gas	11-14" W.C. (27.4-34.9mbar)	-	-	-	-	-	150,000 BTU (44kW-hr.)	
	G20	-	20mbar	20mbar	-	20-25mbar	20mbar	44kW-hr.	
	G25	-	-	20mbar	25mbar	-	-	44kW-hr.	
	G20, G25	-	20mbar	20mbar	25mbar	20-25mbar	20mbar	44kW-hr.	
	G30	-	29-37mbar	-	28-30mbar	29-37mbar	50mbar	44kW-hr.	
	G30, G31	-	-	50mbar	30mbar	-	50mbar	44kW-hr.	

The required gas supply pressures of other locations are dependent on the local gas type and on all applicable local codes.

Minimum Gas Pipe Sizes:

- Natural Gas - 2" (50.8mm) main supply line. One 1-1/4" (12.7mm) NPT branch to lower oven cavity with full-flow shutoff valve.
- Propane Gas - 2" (50.8mm) main supply line. One 1-1/4" (12.7mm) NPT branch to lower oven cavity with full-flow shutoff valve.

ALL SPECIFICATIONS SUBJECT TO CHANGE WITHOUT NOTICE.